

Items Supplied >

- 1 - INTAKE COVER W/ INTAKE SCREEN ASSEMBLY
- 1 - K&N® VENTURI AIR FILTER
- 1 - BILLET VELOCITY STACK
- 1 - MOUNTING PLATE
- 1 - SUPPORT BRACKET
- 1 - INTAKE GASKET
- 2 - O-RING, SILICONE
- 2 - BREATHER BOLT, 3/8"-16 X 1"
- 3 - BOLT, 1/4"-20 X 7/8", BUTTONHEAD W/ LOCK PATCH
- 3 - BOLT, 1/4"-20 X 5/8", HEX FLANGE
- 3 - LOCK WASHER, 1/4" TOOTHED
- 1 - ZIPTIE, 4" #18 TEST

Application(s) >

HARLEY:	
SOFTAIL	2000-13
ROCKER	2008-11
DYNA	2000-13
DYNA SWITCHBACK	2012-13

Instruction Manual >

606-0102

Page 1 of 2

Read all instructions carefully and completely before installing your new POWRFLO™ Intake.

1. Remove the allen bolt from the center of the stock air cleaner to remove the cover. Remove the (3) bolts securing the air filter. Then remove and discard the air filter, air box and seals/gaskets.
NOTE: For 2012 Dyna models, disengage the wire connector and cap from the backside of the air box.
2. Remove and discard the (2) stock breather bolts and (2) stock o-rings from the cylinder heads; save the breather hoses for reuse during installation.
3. Insert (3) supplied 1/4"-20 x 3/4" buttonhead bolts with lock washers through the mounting holes in the velocity stack and mounting plate. While holding that assembly together with one hand, insert the (2) breather hoses through the mounting plate and into the velocity stack with the hoses rotated outward, as shown in Figure 1. Make sure the hoses are bottomed out in the back of the velocity stack.
4. Join together the assembly from Step 3 with the supplied support bracket and gasket then start threading the (3) buttonhead bolts into the throttle body, but do not tighten.

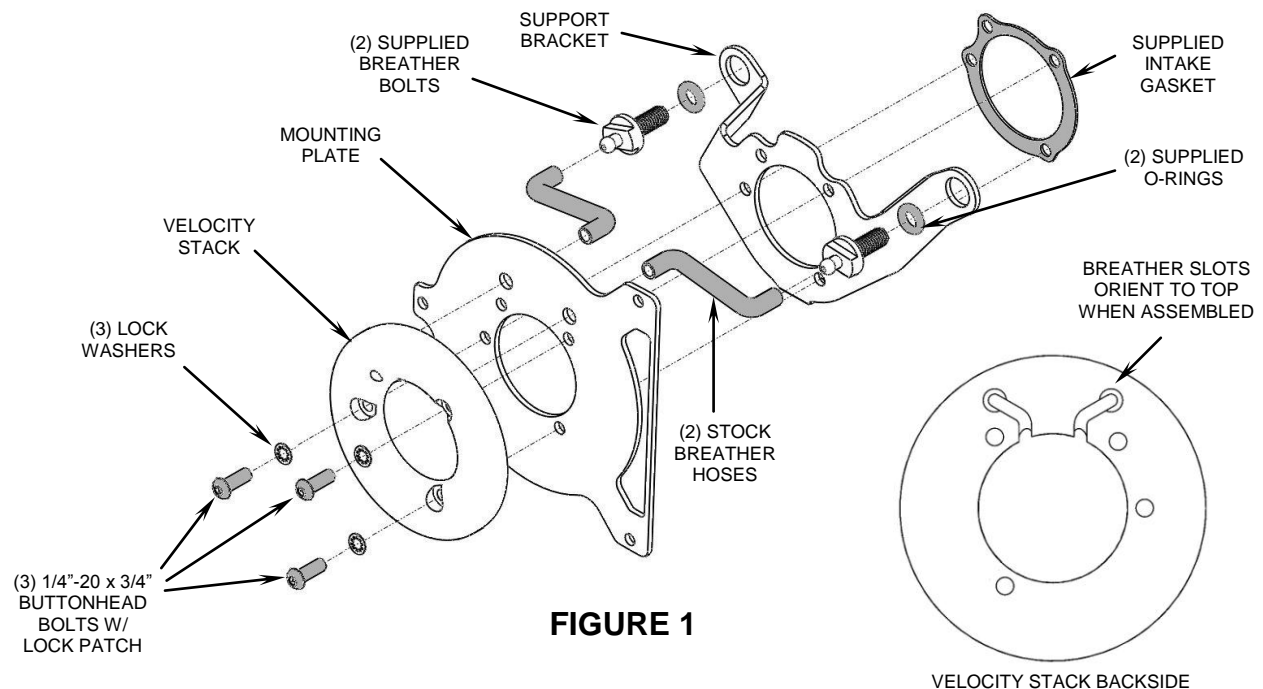

* Cobra® recommends you always wear a helmet while riding. Please never operate your motorcycle while under the influence of alcohol and/or drugs. Enjoy the new look of your motorcycle and please ride safely.

5. Place a supplied o-ring onto both supplied breather bolts. Insert the breather bolts through the support bracket openings and into the cylinder heads and lightly snug. Now snug the (3) buttonhead bolts evenly, and then fully tighten them to the throttle body. Tighten the (2) breather bolts.
6. Insert outer end of rubber hoses over nipples on breather bolts.
7. **For 2012 Dyna models** use the supplied ziptie to secure the wire connector/cap to the support bracket tab. See Figure 2. *NOTE: Secure ziptie around the connector, DO NOT ziptie around wires.*
8. Place the supplied K&N® filter onto the velocity stack. Insert the intake screen assembly into the POWRFLO™ intake cover so the holes in the bent tabs align with the threaded bosses.
9. Place the intake cover over the air filter and align threaded bosses with the mounting plate holes. Insert the (3) supplied 1/4"-20 x 5/8" hex flange bolts through the mounting plate, intake screen and into the intake cover then tighten. See Figure 3.

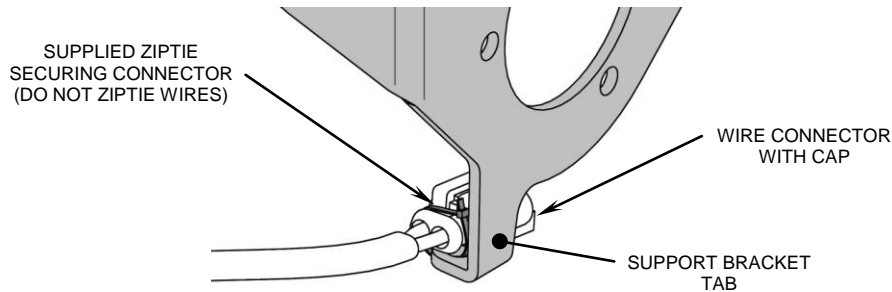

FIGURE 2

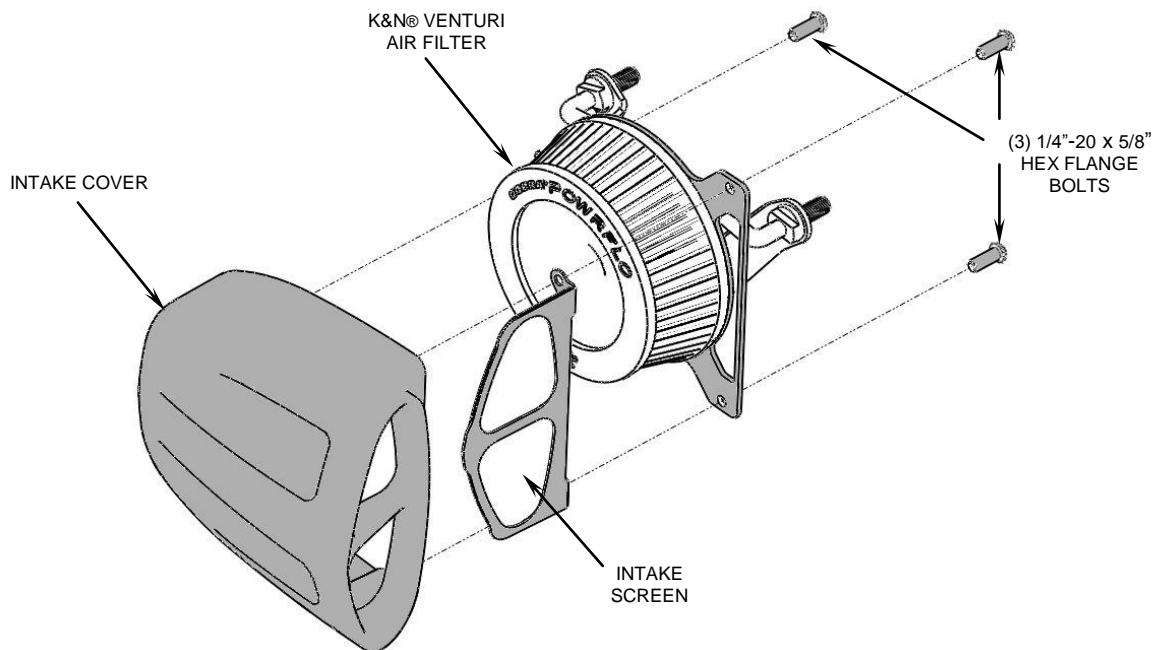

FIGURE 3

IMPORTANT: To achieve optimum performance from your new POWRFLO™ Air Intake it is suggested that you install a Cobra Fi2000® Digital Fuel Processor. Visit www.fi2000r.com